

Digital Temperature Indicating Controller

BCS1 series



■ Features

- 48 x 48mm
Temperature indicating controller
- Money saving
- Space saving
- Made in Japan

■ Model

Series	BCS1	BCS1	R	-	0	0	M00	-	0	000000000-00
Control output (OUT)	Relay contact		R							
	Non-contact voltage		S							
Supply voltage	100 to 240V AC					0				
Input	Multi-input						M00			
Event output	No Event output								0	
	2 Event outputs								2	

■ Rated scale

Input		Range		Resolution
M	K	-200 to 1370°C	-320 to 2500°F	1°C (°F)
	J	-200 to 1000°C	-320 to 1800°F	1°C (°F)
	Pt100	-199.9 to 850.0°C	-199.9 to 999.9°F	0.1°C (°F)

■ Terminal arrangement

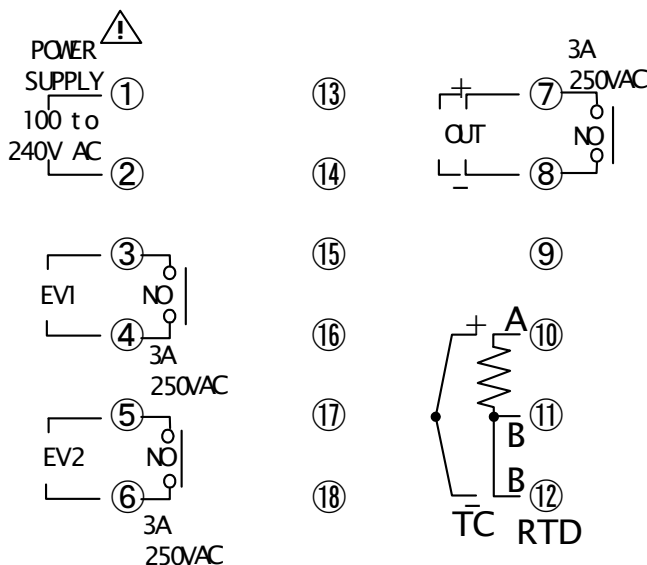

POWER SUPPLY: 100 to 240V AC

EV1 : Event 1 (A1) output (option)

EV2 : Event 2 (A2) output (option)

OUT : Control output

TC : Thermocouple input

RTD : Resistance temperature detector input

Shinjo



(HQ only)

